

The above lights are designed for use on sail or power driven vessels under 20 meters (65.6 ft.) in length, operating at a nominal 12 volt or 24 volt system. In order to comply with the '72 COLREGS and the U.S. Inland Rules, the following must be adhered to:

MOUNTING INFORMATION
Read all instructions before proceeding.

- For proper light selection, positioning and configuration, refer to A.B.Y.C. Standard A-16*, the '72 COLREGS*, and the U.S. Inland Rules*. These lights are usually supplied complete with 12 volt bulbs (Cat. No. 0071DPOCLR, 12V, 10W), however, 24 volt bulbs (Cat. No. 0072DP1CLR, 24V, 10W) are available for 24 volt systems.
- This light is designed to be mounted on a horizontal surface.
- Draw a 6 inch long reference line through the center of the selected mounting location and parallel to the fore-aft centerline of the boat.
- Cut out the mounting template below. Tape it on to the mounting surface such that the reference line (drawn in Step #3) is directly underneath the reference line marked on the template.
- Drill indicated holes through the template to accommodate #8 mounting screws (pan head for plastic bases & oval head for metal bases) and electrical supply as required.
- Attach supply connections to the light, making sure to wire in accordance with both A.B.Y.C. Standard E-11* and U.S. Coast Guard Safety Standards for Boat Electrical Systems (33 CFR 183)*.

The supply leads are coded as follows:

- WHITE: Forward compartment (masthead light) positive lead.
- Red or GRAY: Aft compartment (when energized with the forward compartment: all-round light) positive supply lead.
- BLACK: Negative supply lead. (CAUTION: Negative lead connected to case. To avoid energizing case, observe polarity).

Electrical connections are to be made such that only the forward compartment (masthead light) is energized with the other running lights (sidelights, stern light, etc.) while underway. Both compartments are energized simultaneously by themselves to create the all-round (anchor) light. Be sure to use double-pole switches otherwise feedback will cause all lights in the system to be energized at the wrong time. See Wiring Diagram.

- Mount the base in accordance with the template.
- Insert the pole into the base and engage the electrical connector. Tighten the black collar. Test the lighting system to ensure desired operation.
- Make sure the top of the light is vertical during operation (See illustration) and the arrow on the top cover points ahead (not astern), with the reference marks parallel to the fore-aft centerline of the boat.
- A cap is provided to protect the base connector when the pole is removed. A cap retainer is also provided to hold the cap while the light is in use, and should be conveniently mounted nearby.

* The above referenced standards can be obtained from:
 (1). American Boat & Yacht Council, Inc.
 613 Third Street, Suite 10
 Annapolis, MD 21403
 (2). U.S. Coast Guard
 Washington, D.C. 20593
 (or your local C.G. office)

MOUNTING TEMPLATE

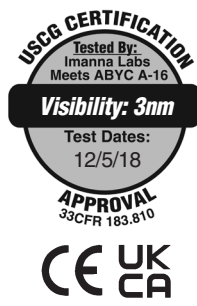
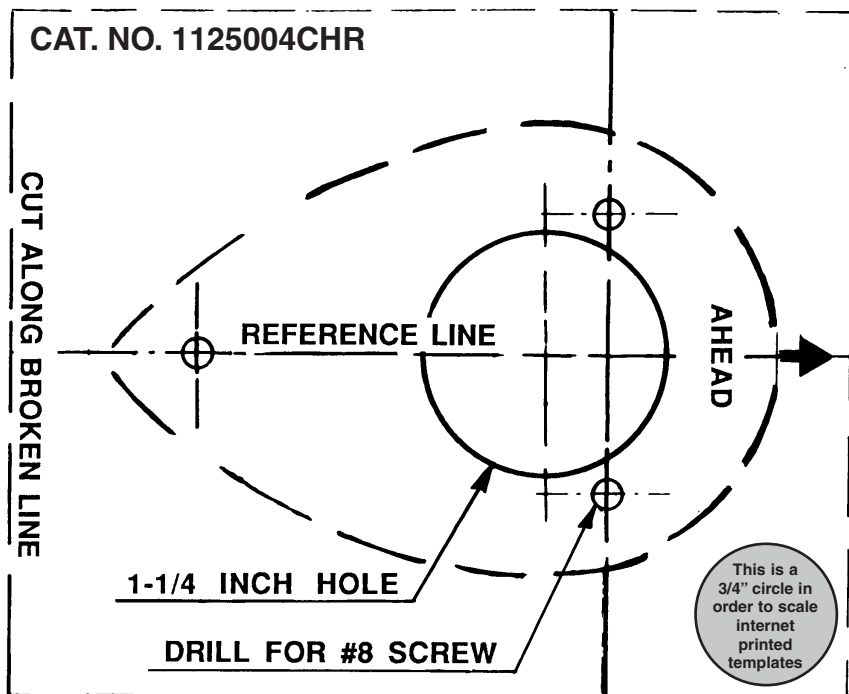

WIRING DIAGRAM FOR COMBINATION MASTHEAD/ANCHOR LIGHTS

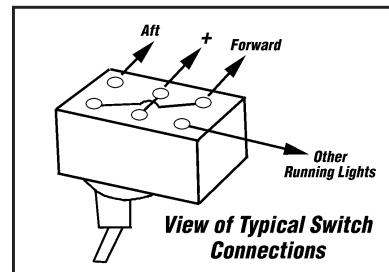
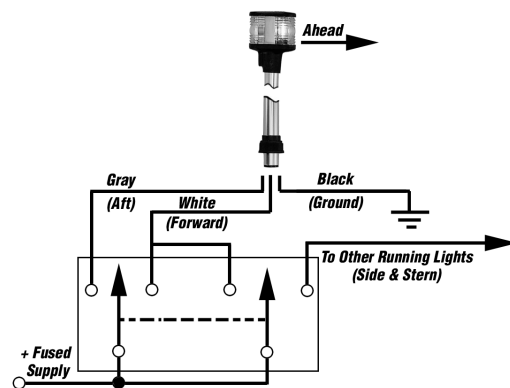

- Double pole, double throw switch (center off)
- One position illuminates running lights (masthead, side & stern)
- Other position illuminates anchor light (forward & aft compartments of combination masthead/anchor light)

NOTE: TOP OF LIGHT MUST BE VERTICAL DURING OPERATION

