

PERKO®

FIVE YEAR LIMITED WARRANTY

PERKO, INC. (PERKO) warrants to the original consumer-purchaser that PERKO'S consumer products will be free from defective materials or workmanship, and that the PERKOPLATE/PERKO-KOTE Finish will remain corrosion-free under normal use and service, for a period of five (5) years from the original purchase date. Products installed as original equipment by a boat builder or manufacturer are limited to one (1) year or the duration of the manufacturer's general accessory warranty, whichever is longer.

ALL IMPLIED WARRANTIES, INCLUDING MERCHANTABILITY, ARE ALSO LIMITED IN DURATION TO THE FIVE YEAR PERIOD FROM THE ORIGINAL PURCHASE DATE.

PERKO SHALL NOT BE LIABLE FOR LOSS OF USE OF ANY OF ITS CONSUMER PRODUCTS, NOR FOR OTHER INCIDENTAL OR CONSEQUENTIAL COSTS, EXPENSES, OR DAMAGES INCURRED BY THE ORIGINAL CONSUMER-PURCHASER OR BY ANY OTHER PERSON.

SOME STATES DO NOT ALLOW LIMITATIONS ON HOW LONG AN IMPLIED WARRANTY LASTS, SO THE ABOVE LIMITATION MAY OR MAY NOT APPLY TO YOU. SOME STATES DO NOT ALLOW THE EXCLUSION OR LIMITATION OF INCIDENTAL OR CONSEQUENTIAL DAMAGES, SO THE ABOVE LIMITATION OR EXCLUSION MAY OR MAY NOT APPLY TO YOU.

This warranty is void if the consumer product warranted has been damaged by accident or unreasonable use, neglect, improper service or other cause not arising out of defects in material or workmanship. Excluded from this warranty are Electric Light Bulbs (lamps), Sealed Beam Units and Fuses.

During the warranty period, your PERKO product will either be repaired or it will be replaced with a like product (at PERKO'S option) without charge to the original consumer-purchaser, when returned prepaid and insured, with proof-of-purchase date to PERKO at the address shown below. In the event of replacement, the replacement product will continue the warranty of the original product, or ninety (90) days, whichever is longer.

PERKO does not authorize any person or company to create for it any other obligation or liability in connection with any of its products.

PERKO, INC

16490 N.W. 13TH AVENUE • MIAMI, FL 33169-5707
www.perko.com



PERKO®



8500 Series Battery Selector Switch Installation Instructions



**Fig 8501
Selector Switch**



**Fig 8502
Selector Switch
with Key Lock**



**Fig 8503
Selector Switch
with Alternator Field
Disconnect**



**Fig 8504
Selector Switch
with Key Lock and
Alternator Field Disconnect**



**Optional Cable Spacer
Fig. 0462 Spacer**

For use with large cables or when additional clearance to the mounting surface is required

BATTERY SWITCHES
INSTALLATION AND OPERATING INSTRUCTIONS

For use with alternators and generators rated 6-32 V.D.C. switch rating: 250 amperes continuous, 360 intermittent. Locate switch to keep battery cables short as possible.

All wiring to the switch shall be performed by a QUALIFIED MARINE ELECTRICIAN, and in accordance with the "Fire Protection Standard For Motor Craft", N.F.P.A.* No. 302, The Standards of the American Boat and Yacht Council, Inc.*, and the U.S.C.G.* Safety Standards for Boat Electrical Systems (33 CFR 183).

CAUTION: (1) Make sure connections at terminals No.1 and No. 2 are of the same polarity.
 (2) Always STOP engines before switching to "OFF" position. Make-Before-Break feature allows switching between 1-all-2 positions with running engines.

Erratic operation, particularly after very long periods of idleness, can be cleared by rapidly switching back and forth briskly several times with out any load connected.

NOTE: (1) Locate switch to keep battery cables short as possible.
 (2) If switch is to be mounted in an area subject to corrosion, it is recommended that a liquid electrical coating be applied to the terminal connections.
 (3) Terminal stud size is 5/16 inch. Torque terminal nuts to 10 ft-lbs.
 (4) Mounting screw size #10 pan head or round head. Do not over-tighten screws to prevent deforming the switch.

OPTIONAL ACCESSORIES

- (1) Key Lock - Switch can be locked only in the "OFF" position. Key can be removed in either the locked or unlocked position.
- (2) Alternator Field Disconnect - used to break the field current and protect the alternator diodes if the battery switch is inadvertently turned to the "OFF" position with the engine running. Hook-up instructions and applicability are explained in Diagram #4.
- (3) Optional cable spacer (Dealer Pack: 0462DP0RED or Bulk Pack: 0462000RED) available for use with large or heavy-duty cables, when additional space is required between terminals and mounting surface.

The following diagrams illustrate typical installations.

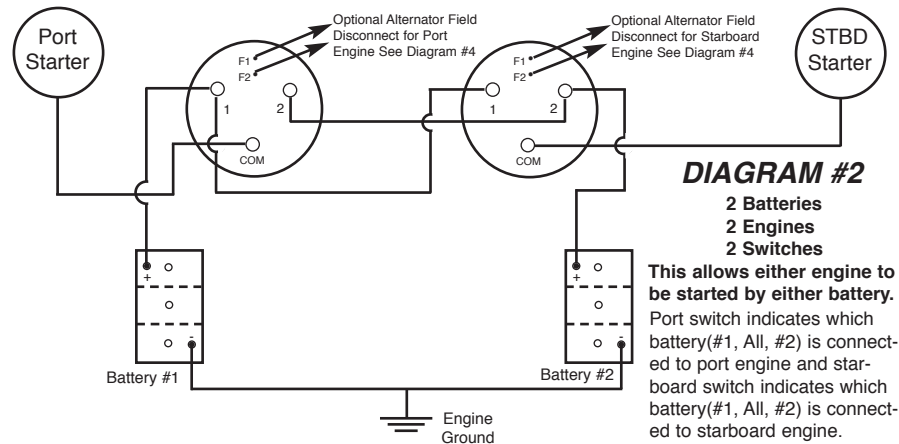
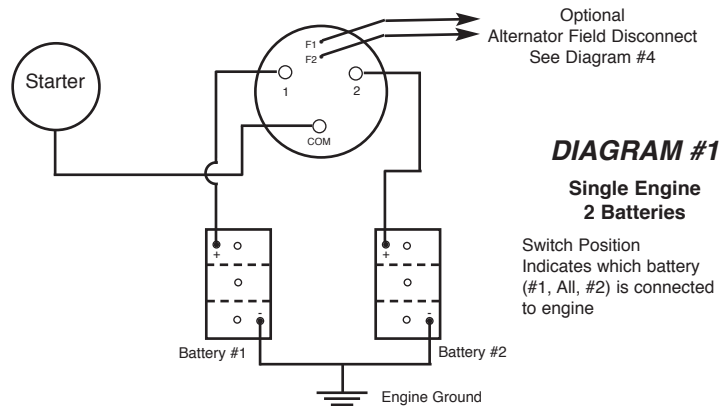

DIAGRAM #3

**2 Switches
 2 Engines
 2 Engine Batteries and separate bank of lighting batteries**

This allows both engines to be used to charge lighting batteries.

Port switch indicates which battery (Port only, Port Lighting only) is connected to port engine and the starboard switch indicates which battery (Starboard only, Starboard Lighting only) is connected to starboard engine.

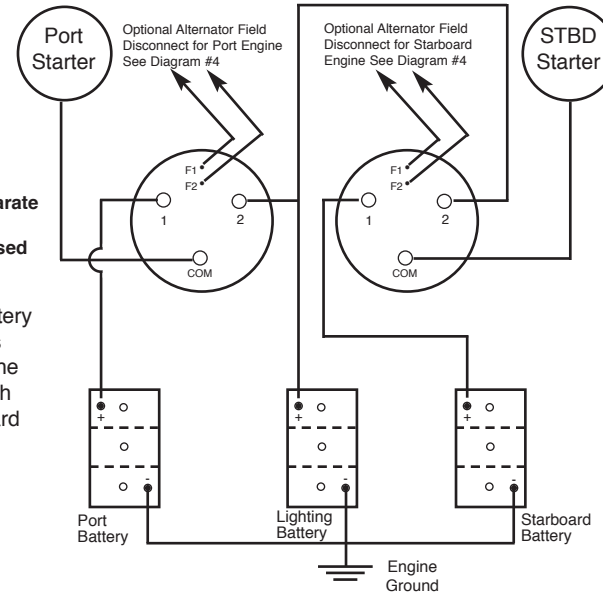
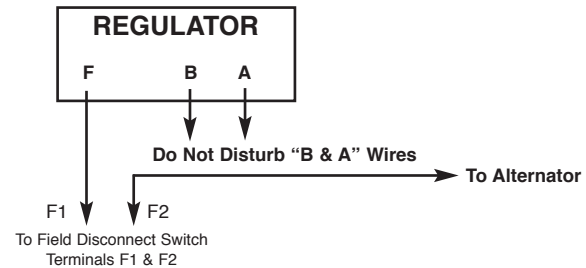

DIAGRAM #4

ALTERNATOR FIELD DISCONNECT

- A. Use minimum 14 awg wire, suitable for use in marine engine compartments.
- B. On systems with separate regulator, splice the field disconnect switch into the field wire "F" as shown:

1. At the Regulator:



2. At the Alternator:

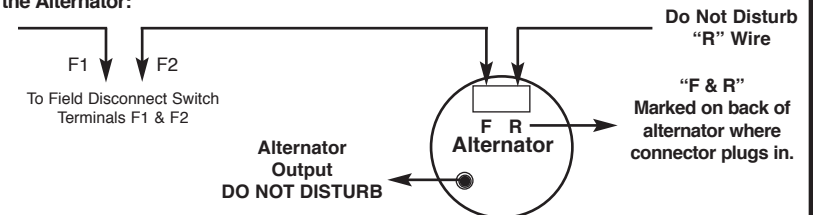

C. On unitized alternators with built-in regulator - a field disconnect cannot be installed.

- 1. American Boat & Yacht Council, Inc.
 613 Third Street, Suite 10
 Annapolis, MD 21403
- 2. U.S. Coast Guard
 Washington, D.C. 20593
 (or your local C.G. office)
- 3. N.F.P.A.
 1 Batterymarch Park
 Quincy, MA 02269