

# PERKO Cat. No. 1428 (Angled Neck) Flip Top Series Sealed EPA Fill with Vacuum Pressure Relief (VPR) for EPA Fuel Systems

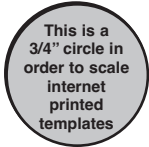

These fills meet the CARB and EPA requirements of U.S.C.G. Safety Standards (July 31, 2011) for 40 CFR Parts 9, 60, 80 et al. Control of Diurnal Emissions From Nonroad Spark-Ignition Engines and Equipment.

**WARNING** Do not attempt to use these non-vented EPA fills on older vented non-EPA certified boats. Although similar in appearance, the cap on this fill is not vented whilst the cap on the older version is vented. The vent line attached to this body functions only with the cap open and during the filling process.

**Note:** Inspect the fill components annually for signs of wear. The system will not seal properly if o-ring in cap is cracked or worn. The caps for these fills have a vacuum/ pressure relief valve (VPR) that automatically relieves vacuum and excess pressure in the tank due to expansion and contraction of fuel vapors.

1. Select mounting location:
  - In accordance with A.B.Y.C., U.S. Coast Guard and E.P.A. requirements and regulations.
  - Surface must be flat and provide adequate clearance to remove the cap.
  - Allow for adequate clearance under fill for routing fill and vent hose, which must be selected and installed in accordance with A.B.Y.C. requirements and U.S. Coast Guard Safety Standards for Small Boat Fuel Systems (33 CFR 183).
2. Non-metallic fills do not need to be grounded or bonded.
3. Attach mounting template to selected mounting surface and orient for desired position of fill/vent connections and for ease of insertion of the fuel nozzle into the neck. Drill where indicated, drilling the 3/4 inch hole first.
 

**NOTE: The 2-1/16" dimension of the larger hole is sized to provide mounting surface support to the fill body. DO NOT use larger size cutter or drill.**
4. Mount fill using #10 Round head or Pan head screws. Caulk if necessary.
5. Attach and clamp fill and vent hoses, also in accordance with the above referenced requirements
 

(1). American Boat & Yacht Council, Inc. 613 Third Street, Suite 10 Annapolis, MD 21403	(2). U.S. Coast Guard Washington, D.C. 20593 (or your local C.G. office)	(3). E.P.A. 401 "M" Street S.W. Washington, D.C. 20460
---	--	--

## MOUNTING TEMPLATE

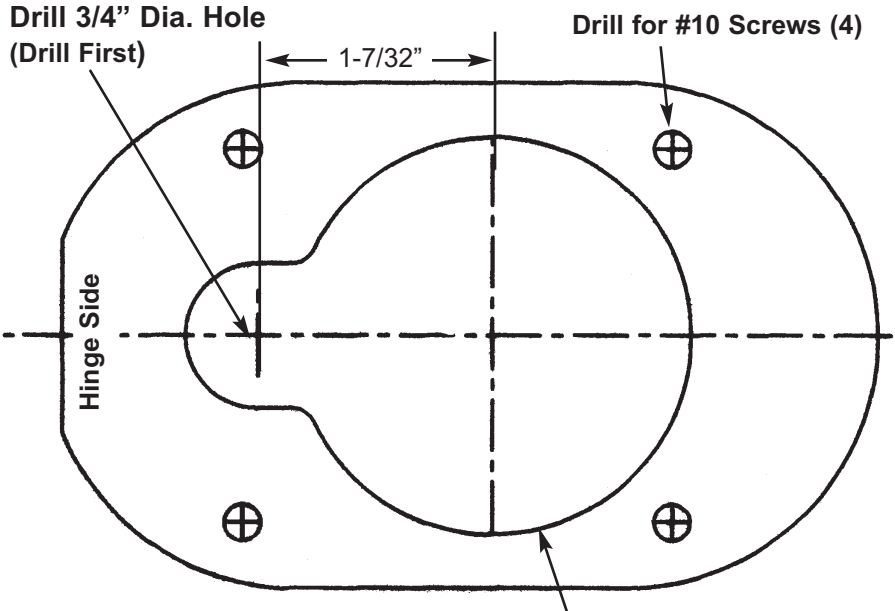

PERKO, INC.  
16490 N.W. 13th Avenue  
Miami, FL 33169-5707  
www.perko.com

**2-1/16" Dia.  
(Drill Second)**